

FIBERER 10km SFP+ Optical Transceiver FPP-31192-LRT

Features

- ◆ Optical interface compliant to IEEE 802.3ae 10GBASE-LR
- ◆ Electrical interface compliant to SFF-8431
- ◆ Hot Pluggable
- ◆ 1310nm DFB transmitter, PIN photo-detector
- ◆ Operating case temperature: -40 to 85 °C Max
- ◆ Low power consumption
- ◆ Applicable for 10km SMF connection
- ◆ All-metal housing for superior EMI performance
- ◆ Advanced firmware allow customer system encryption information to be stored in transceiver
- ◆ Cost effective SFP+ solution, enables higher port densities and greater bandwidth
- ◆ RoHS6 compliant (lead free) 



Applications

- ◆ 10GBASE-LR at 10.3125Gbps
- ◆ Other optical links

Product description

FIBERER SFP+LR 1310nm Transceiver is a “Limiting module”, designed for 10GBASE-LR, and 2G/4G/8G/10G Fiber- Channel applications.

The transceiver consists of two sections: The transmitter section incorporates a DFB laser. And the receiver section consists of a PIN photodiode integrated with a TIA. All modules satisfy class I laser safety requirements. Digital diagnostics functions are available via a 2-wire serial interface, as specified in SFF-8472, which allows real-time access to device operating parameters such as transceiver temperature, laser bias current, transmitted optical power, received optical power and transceiver supply voltage.

Absolute maximum rating

These values represent the damage threshold of the module. Stress in excess of any of the individual Absolute Maximum Ratings can cause immediate catastrophic damage to the module even if all other parameters are within Recommended Operating Conditions.

Parameter	Symbol	Min	Max	Unit
Power Supply Voltage	V _{CC}	0	+3.6	V
Storage Temperature	T _c	-40	+85	°C
Operating Case Temperature	T _c	-40	+85	°C
Relative Humidity	RH	5	95	%

Recommended operating environment

Recommended Operating Environment specifies parameters for which the electrical and optical characteristics hold unless otherwise noted.

Parameter	Symbol	Min.	Typical	Max	Unit
Power Supply Voltage@ -40 to 75°C	V _{CC}	3.135	3.300	3.465	V
	I _{CC}			300	mA
Operating Case Temperature	T _c	-40	25	85	°C
Power Dissipation@ -40 to 75°C	P _D			1	W
Data Rate			10.3125	11.3	Gbps
Transmission Distance				10	km

Low Speed Characteristics

Parameter	Symbol	Min.	Typical	Max	Unit
Power Consumption@ -40 to 75°C				1	W
TX_Fault,RX_LOS	VOL	0		0.4	V
	VOH	Host_Vcc-0.5		Host_Vcc+0.3	V
TX_DIS	VIL	-0.3		0.8	V
	VIH	2.0		VCCT+0.3	V
RS0,RS1	VIL	-0.3		0.8	V
	VIH	2.0		VCCT+0.3	V

Optical characteristics

The following optical characteristics are defined over the Recommended Operating Environment unless otherwise specified.

Parameter	Unit	Values
Operating Reach	Km	10
Transmitter		
Center wavelength (range)	nm	1260 -1355
Side Mode Suppression Ratio (min)	dB	30
Launched power		
maximum	dBm	+0.5
minimum	dBm	-7.2(Notes1)
OMA	dBm	-5.2
OMA-TDP (min)	dBm	-6.2
Transmitter and dispersion penalty	dB	3.2(Notes4)
Average launch power of OFF transmitter (max)	dBm	-30
Extinction ratio (min)	dB	3.5 (Notes2)
RIN ₁₂ OMA (max)	dB/Hz	-128
Optical Return Loss Tolerance (min)	dB	12
Receiver		
Center wavelength (range)	nm	1260-1355
Receive overload (max) in average power ¹	dBm	0.5
Receive sensitivity (min) in average power ¹	dBm	-14.4 (Notes3)
Receiver sensitivity (max) in OMA (footnote 2)	dBm	-12.6 (Notes3)
Receiver Reflectance (max)	dB	-12
Stressed receiver sensitivity (max) in OMA ²	dBm	-10.3
Vertical eye closure penalty (min) ³	dB	2.2
Stressed eye jitter (min) ²	Ulp-p	0.7
Receive electrical 3dB upper cutoff frequency (max)	GHz	12.3
Receiver power (damage, Max)	dBm	4
Notes:		
1. The optical power is launched into SMF		
2. Measured with a PRBS 2 ³¹ -1 test pattern@10.3125Gbps		
3. Measured with a PRBS 2 ³¹ -1 test pattern@10.3125Gbps BER≤10 ⁻¹²		
4. In G.652 and G.655(NDSF)		

Electrical characteristics

The following electrical characteristics are defined over the Recommended Operating Environment unless otherwise specified.



Parameter	Symbol	Min	Typical	Max	Unit	
Data Rate		-	10.3125	-	Gbps	
Power Consumption		-	800	1000	mW	
Transmitter						
Single Ended Output Voltage Tolerance		-0.3	-	4.0	V	
C common mode voltage tolerance		15	-	-	mV	
Tx Input Diff Voltage	VI	400		1600	mV	
Tx Fault	VoL	-0.3		0.4	V	At 0.7mA
Data Dependent Input Jitter	DDJ			0.10	UI	
Data Input Total Jitter	TJ			0.28	UI	
Receiver						
Single Ended Output Voltage Tolerance		-0.3	-	4.0	V	
Rx Output Diff Voltage	Vo	300		850	mV	
Rx Output Rise and Fall Time	Tr/Tf	28			ps	20% to 80%
Total Jitter	TJ			0.70	UI	
Deterministic Jitter	DJ			0.42	UI	

Digital Diagnostic Functions

The following digital diagnostic characteristics are defined over the Recommended Operating Environment unless otherwise specified. It is compliant to SFF8472 Rev9.2 with internal calibration mode. For external calibration mode please contact our sales staff.

Parameter	Symbol	Min.	Max	Unit	Notes
Accuracy					
Transceiver Temperature	DMI_Temp	-3	+3	degC	Over operating temp
TX Output optical power	DMI_TX	-3	+3	dB	
RX Input optical power	DMI_RX	-3	+3	dB	-3dBm to -15dBm range
Transceiver Supply voltage	DMI_VCC	-0.08	+0.08	V	Full operating range
Bias current monitor	DMI_Ibias	-10%	10%	mA	
Dynamic Range Accuracy					
Transceiver Temperature	DMI_Temp	-5	70	degC	
TX Output optical power	DMI_TX	-9	-1	dBm	
RX Input optical power	DMI_RX	-18	0	dBm	
Transceiver Supply voltage	DMI_VCC	3.0	3.6	V	
Bias current monitor	DMI_Ibias	0	100	mA	

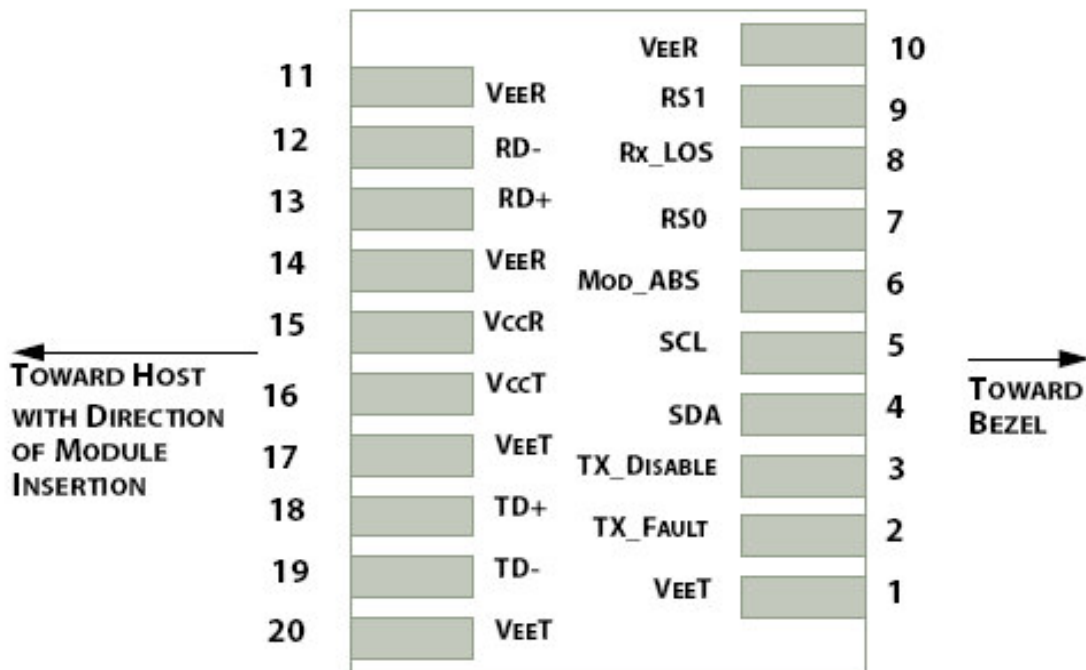

Figure 1: Interface to Host PCB

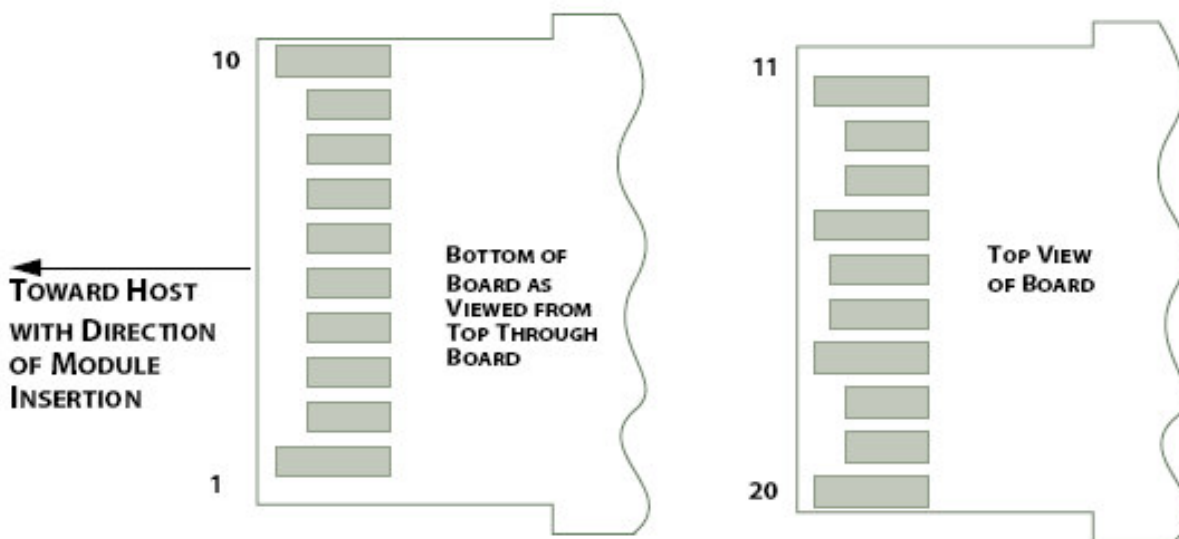

Figure 2: Module Contact Assignment

Pin definition

Pin	Symbol	Name/Description
1	VEET [1]	Transmitter Ground



2	Tx_FAULT [2]	Transmitter Fault
3	Tx_DIS [3]	Transmitter Disable. Laser output disabled on high or open
4	SDA [2]	2-wire Serial Interface Data Line
5	SCL [2]	2-wire Serial Interface Clock Line
6	MOD_ABS [4]	Module Absent. Grounded within the module
7	RS0 [5]	Rate Select 0
8	RX_LOS [2]	Loss of Signal indication. Logic 0 indicates normal operation
9	RS1 [5]	Rate Select 1
10	VEER [1]	Receiver Ground
11	VEER [1]	Receiver Ground
12	RD-	Receiver Inverted DATA out. AC Coupled
13	RD+	Receiver DATA out. AC Coupled
14	VEER [1]	Receiver Ground
15	VCCR	Receiver Power Supply
16	VCCT	Transmitter Power Supply
17	VEET [1]	Transmitter Ground
18	TD+	Transmitter DATA in. AC Coupled
19	TD-	Transmitter Inverted DATA in. AC Coupled
20	VEET [1]	Transmitter Ground

Notes:

[1] Module circuit ground is isolated from module chassis ground within the module.

[2].should be pulled up with 4.7k – 10k ohms on host board to a voltage between 3.15V and 3.6V.

[3]Tx_Disable is an input contact with a 4.7 kΩ to 10 kΩ pullup to VccT inside the module.

[4]Mod_ABS is connected to VeeT or VeeR in the SFP+ module. The host may pull this contact up to Vcc_Host with a resistor in the range 4.7 kΩ to 10 kΩ. Mod_ABS is asserted “High” when the SFP+ module is physically absent from a host slot.

[5] RS0 and RS1 are module inputs and are pulled low to VeeT with > 30 kΩ resistors in the module.

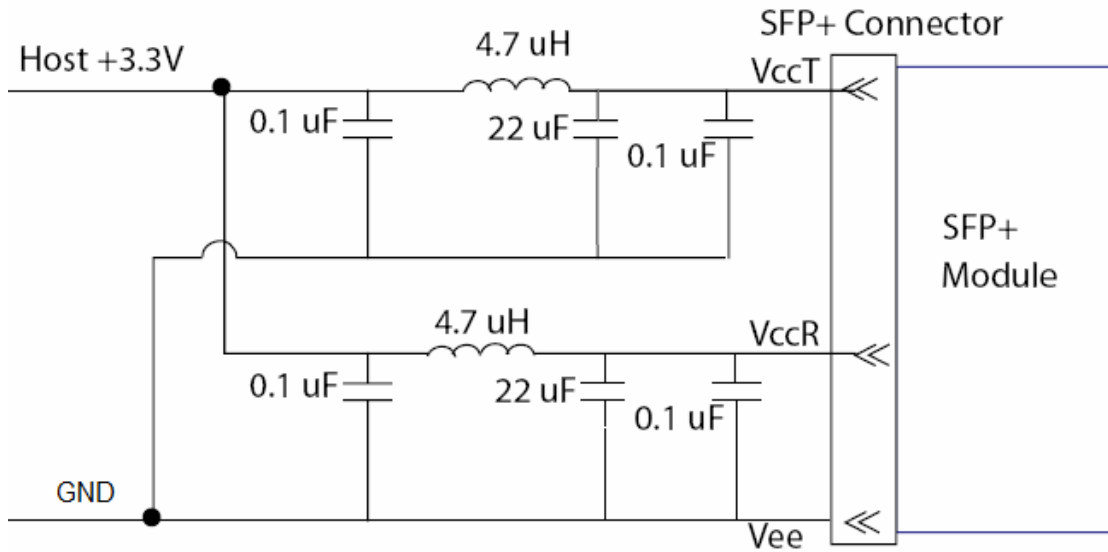

Figure3. Host Board Power Supply Filters Circuit

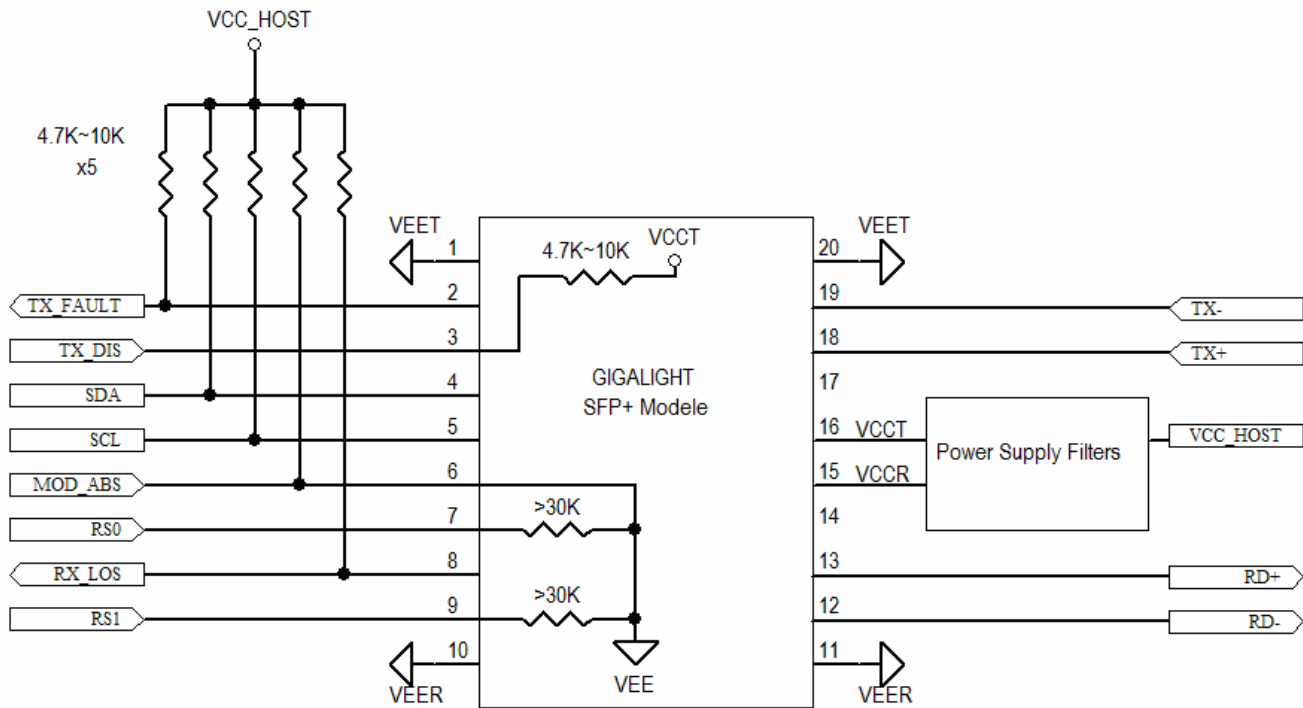

Figure4. Host-Module Interface

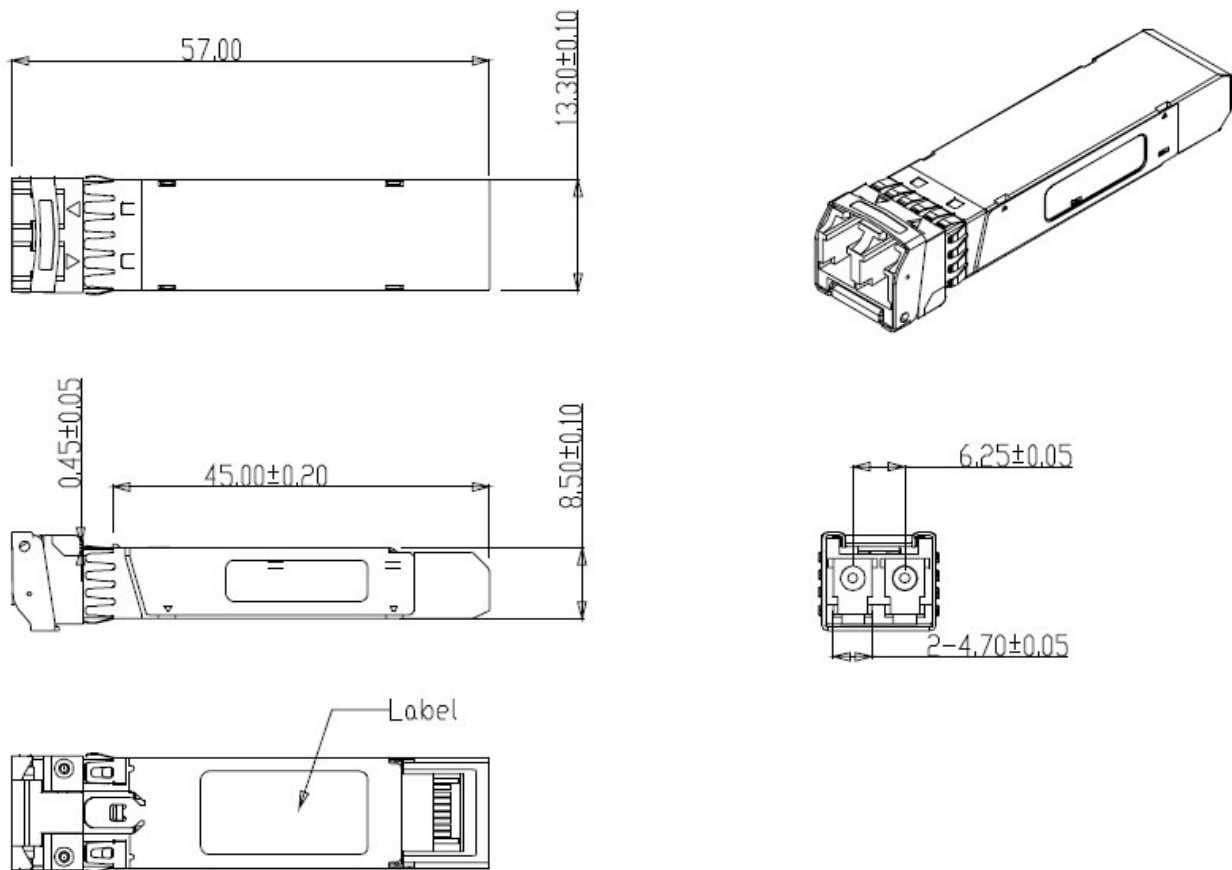

Figure5. Mechanical Specifications

Regulatory Compliance

FIBERER SFP+ transceiver is designed to be Class I Laser safety compliant and is certified per the following standards:

Feature	Agency	Standard	Certificate / Comments
Laser Safety	FDA	CDRH 21 CFR 1040 and Laser Notice No. 50	1120292-000
Product Safety	UL	UL and CUL EN60950-2:2007	E347511
Environmental protection	SGS	RoHS Directive 2002/95/EC	GZ1001008918/CHEM
EMC	WALTEK	EN 55022:2006+A1:2007 EN 55024:1998+A1+A2:2003	WT10093759-D-E-E



Ordering information

Part Number	Product Description
FPP-31192-LRT	1310nm, 10Gbps, SFP+ 10km, 0°C ~ +70°C ; -40°C ~ +85°C

References

1. "Specifications for Enhanced Small Form Factor Pluggable Module SFP+", SFF-8431, Rev 4.1, July 6, 2009.
2. "Improved Pluggable Formfactor", SFF-8432, Rev 4.2, Apr 18, 2007
3. IEEE802.3ae – 2002
4. "Diagnostic Monitoring Interface for Optical Transceivers" SFF-8472, Rev 10.3, Dec 1, 2007

Important Notice

Performance figures, data and any illustrative material provided in this data sheet are typical and must be specifically confirmed in writing by FIBERER before they become applicable to any particular order or contract. In accordance with the FIBERER policy of continuous improvement specifications may change without notice.

The publication of information in this data sheet does not imply freedom from patent or other protective rights of FIBERER or others. Further details are available from any FIBERER sales representative.

Copyright@ Fiberer Global Tech Ltd.

Our Spiritual Mission

To facilitate User's network and testing systems more successful, let the world more beautiful by our high quality and stability of products and VIP service.

Production Capacity

The quantity of our staff is more than 2,800 and the workshop area is 6,000 square meters. We have a 10,000 level of purifications production workshop about 3000 square meters, and the production capacity is above 5000pcs/week on fiber-optic modules and components.

Email: engineer@fiberer.com

Website: <http://www.sfp-module.com>